



Hoërskool Johan Jurgens

Physical Science Gr. 12

9 March 2026

Control Test – Term 1

Marks: 100

Time: 2 hours

Examiner: S Stoltz

Moderator: N Gertenbach

INSTRUCTIONS AND INFORMATION

1. The question paper consists of six questions. Answer ALL the questions.
2. Start EACH question on a NEW page.
3. Number your answers correctly according to the numbering system used in this question paper.
4. Leave ONE line between two sub-questions, e.g., between QUESTION 2.1 and QUESTION 2.2.
5. A non-programmable calculator may be used.
6. Appropriate mathematical instruments may be used.
7. Show ALL formulae and substitutions in ALL calculations.
8. Round off your FINAL numerical answers to a minimum of TWO decimal places.
9. Give brief motivations, discussions, etc. where required.
10. You are advised to use the attached data sheets.
11. Write neatly and legibly.

QUESTION 1: MULTIPLE-CHOICE QUESTIONS

Four options are provided as possible answers to the following questions. Choose the answer and write only the letter (A – D) next to the question number (1.1 – 1.7).

1.1 An object is thrown vertically upwards. Which ONE of the following regarding the object's acceleration at the highest point of its motion is CORRECT? Ignore the effects of friction.

- A. $0 \text{ m}\cdot\text{s}^{-2}$
- B. $-9,8 \text{ m}\cdot\text{s}^{-2}$, downwards
- C. $9,8 \text{ m}\cdot\text{s}^{-1}$, downwards
- D. $9,8 \text{ m}\cdot\text{s}^{-2}$, downwards (2)

1.2 A ball is dropped from rest and reaches a velocity v after it has travelled **3 m**. What will the magnitude of the velocity of the ball be after it has travelled **9 m**. Ignore the effects of friction.

- A. $\frac{1}{3}v$
- B. $\sqrt{3}v$
- C. $3v$
- D. $6v$ (2)

1.3 An object is thrown upwards with an unknown velocity. The velocity time graph below shows the entire motion of the object.

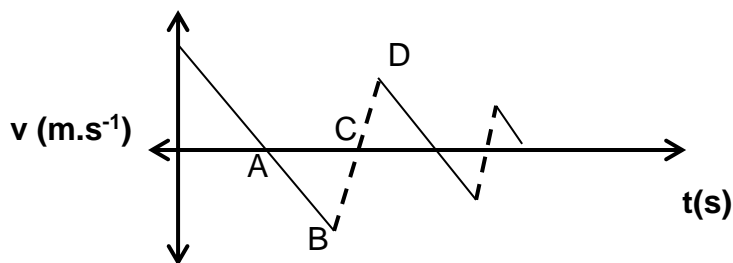

At which point A – D will the object have the greatest momentum?

- A. A
- B. B
- C. C
- D. D (2)

- 1.4 The magnitude of the gravitational force exerted by one body on another is F . When the distance between the centres of the two bodies is halved and the mass of one body is doubled, the magnitude of the gravitational force, in terms of F , will now be:
- A. $\frac{1}{4}F$
 - B. $\frac{1}{8}F$
 - C. $2F$
 - D. $8F$ (2)
- 1.5 A larger impulse results from:
- A. Large force for short time
 - B. Small force for long time
 - C. Large force for long time
 - D. No force (2)
- 1.6 Which one of the following compounds has the lowest vapour pressure?
- A. Propene
 - B. Propan-1-ol
 - C. Propanoic acid
 - D. Propanone (2)
- 1.7 Which of the following organic compounds has no structural isomers?
- A. Propane
 - B. Propan-1-ol
 - C. Propanal
 - D. Propanoic acid (2)

[14]

QUESTION 2: NEWTON'S LAWS

Block **A** with a mass of 6 kg on a horizontal surface is connected to block **B** with an unknown mass (m) along a rough inclined plane at an angle of 30° by means of an inextensible string passing over a frictionless pulley. A constant force of 35 N is applied on block **A** at an angle of 20° to the horizontal causing the two blocks to move with a CONSTANT VELOCITY as indicated below.

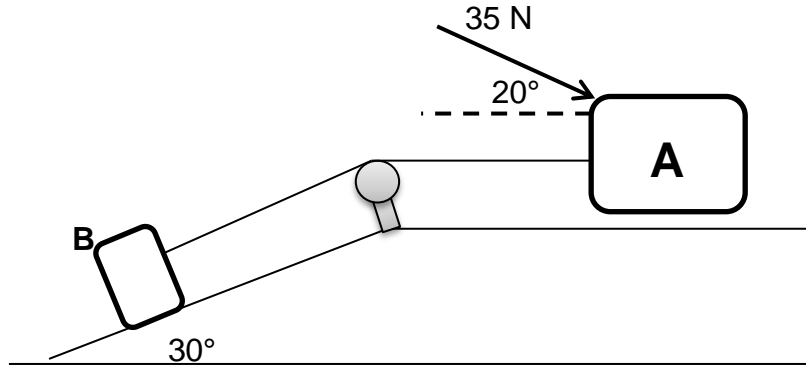

The coefficient of kinetic friction on block **A** is 0,2 and for block **B** it is 0,15.

- 2.1 State *Newton's second law of motion* in words. (2)
- 2.2 Draw a labelled free body diagram indicating ALL the forces acting on block **A**. (5)
- 2.3 Calculate the magnitude of the:
 - 2.3.1 Tension between the two blocks. (4)
 - 2.3.2 Mass of block **B**. (4)

[15]

QUESTION 3: VERTICAL PROJECTILES

A ball is thrown vertically upwards from the edge (top) of a building and bounces a few times as it hits the ground. The displacement – time graph describes the motion of the ball from the time it is thrown, up to a certain time T (maximum height). The motion of the ball is observed from the point of launch. Ignore the effects of air friction.

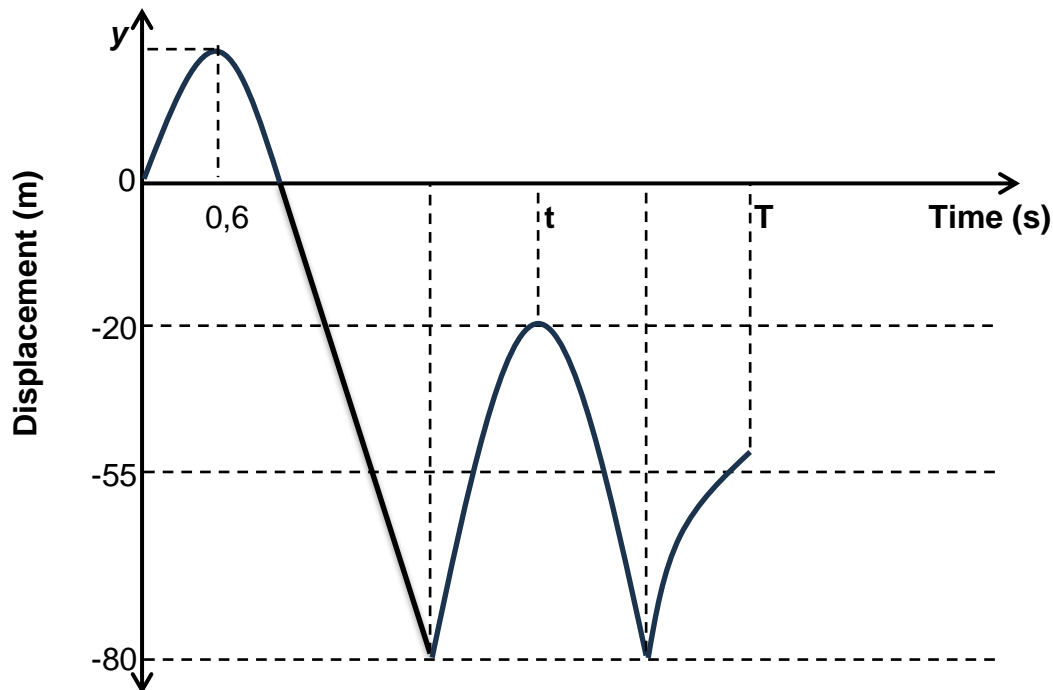

- 3.1 Define the term *free fall*. (2)
- 3.2 Write down the:
- 3.2.1 Height above the ground from where the ball was thrown upwards. (1)
- 3.2.2 Acceleration of the ball at $t = 0,6$ s. (2)
- 3.3 Calculate the:
- 3.3.1 Velocity at which the ball is thrown upwards. (3)
- 3.3.2 Maximum height the ball reaches above the ground after the SECOND bounce. (2)
- 3.3.3 Velocity at which the ball leaves the ground after the FIRST bounce. (3)
- 3.3.4 Numerical value of time (t) as shown on the graph. (5)

- 3.4 Draw a velocity – time graph for the motion of the ball from the instant it is thrown upwards until it reaches its maximum height after the first bounce (time, t).

Indicate the following on the graph:

- Initial velocity of the ball.
- Velocity at which it leaves the ground after the first bounce.
- Time taken to reach maximum height for the first time. (4)

[22]

QUESTION 4: MOMENTUM AND IMPULSE

The vector diagrams below show the momentums of car **A**, mass 2 000 kg, which is traveling to the right, before and after a head-on collision with stationary car **B**. The collision lasted 0,5 seconds. After the collision, car **B** moves to the right with a speed of $20 \text{ m}\cdot\text{s}^{-1}$.

The diagrams below are not drawn to scale.

VECTOR DIAGRAM FOR CAR A BEFORE AND AFTER COLLISION

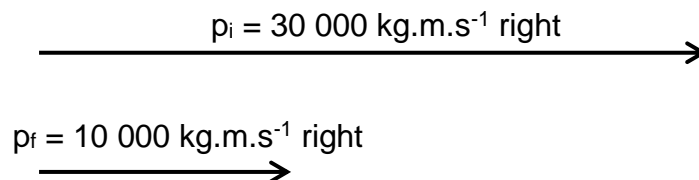

- 4.1 State the *principle of conservation of linear momentum* in words. (2)
- 4.2 Calculate the:
- 4.2.1 Velocity of car **A** before the collision. (3)
- 4.2.2 Mass of car **B**. (4)
- 4.3 Draw a labelled vector diagram showing the magnitude and direction of the change in momentum of car **A**. (2)
- 4.4 Calculate the magnitude of the net force that car **A** exerts on car **B**. (3)
- 4.5 Use the impulse-momentum theorem to explain how an airbag, which inflates between the driver and the steering wheel of a car during a collision, protects the driver. (3)

[17]

QUESTION 5: ORGANIC CHEMISTRY

The letters **A** to **G** in the table below represents seven organic compounds.

| | | | |
|----------|---|----------|--|
| A | $\text{CH}_3\text{CH}_2\text{COOCH}_3$ | B | $\text{C}_3\text{H}_8\text{O}$ |
| C | $ \begin{array}{cccc} & \text{H} & \text{H} & \text{H} & \text{O} \\ & & & & // \\ \text{H} & - \text{C} & - \text{C} & - \text{C} & - \text{C} \\ & & & & \\ & \text{H} & \text{H} & \text{H} & \text{H} \end{array} $ | D | 3,3-difluorohexane |
| E | $ \begin{array}{cccccc} & & & \text{CH}_3 & & \\ & & & & & \\ \text{CH}_3 & & \text{Cl} & & \text{H} & \text{H} \\ \diagdown & & & & & \\ \text{H} - \text{C} & - \text{C} & - \text{C} & - \text{C} & - \text{C} & - \text{H} \\ & & & & \diagdown & \\ \text{Cl} & \text{H} & \text{H} & \text{CH}_3 & \text{CH}_3 & \end{array} $ | F | $\text{CH}_3(\text{CH})_2\text{CH}_2\text{CH}_3$ |
| G | 3-methylbutan-2-one | | |

- 5.1 Define the term *functional group*. (2)
- 5.2 Write the STRUCTURAL FORMULA of the FUNCTIONAL GROUP to which compound **A** belongs. (1)
- 5.3 Write the:
- 5.3.1 Letter that represents an UNSATURATED hydrocarbon. (1)
- 5.3.2 IUPAC name of compound **C**. (2)
- 5.3.3 IUPAC name of compound **E**. (3)
- 5.3.4 STRUCTURAL FORMULA of compound **G**. (2)
- 5.3.5 STRUCTURAL FORMULA of compound **D**. (2)
- 5.4 Compound **B** has two STRUCTURAL ISOMERS.
- 5.4.1 Define the term *structural isomer*. (2)
- 5.4.2 Write down the IUPAC names of these compounds. (2)
- 5.5 Write down the NAMES of any two homologous series that can be FUNCTIONAL ISOMERS. (2)

QUESTION 6: ORGANIC CHEMISTRY

Factors that affect vapour pressure are investigated. The vapour pressure of compounds **A**, **B**, **C**, and **D** from two different homologous series are determined and shown in the table.

| COMPOUND | | VAPOUR PRESSURE (kPa) | MOLECULAR MASS (g.mol ⁻¹) |
|----------|-------------|-----------------------|---------------------------------------|
| A | Propane | 853,16 | 44 |
| B | Butane | 112 | 58 |
| C | Propan-1-ol | 2,4 | 60 |
| D | Butan-1-ol | 0,1 | 74 |

- 6.1 Define the term *homologous series*. (2)
- 6.2 Write down the homologous series to which compound **C** belongs. (1)
- 6.3 In one investigation the vapour pressure of compound **C** and **D** are compared. Write down the:
- 6.3.1 Independent variable. (1)
- 6.3.2 Dependant variable. (1)
- 6.3.3 Conclusion that can be drawn. (2)
- 6.4 Refer to the TYPE and the STRENGTH of the intermolecular forces to explain the difference in vapour pressure of butane and butan-1-ol. (3)
- 6.5 Which ONE of the compounds **A**, **B**, **C**, or **D** has the highest boiling point? Explain your answer. (3)

[13]**PAPER TOTAL: 100 MARKS**

DATA FOR PHYSICAL SCIENCES GRADE 12
PAPER 1 (PHYSICS)
GEGEWENS VIR FISIESTE WETENSKAPPE GRAAD 12
VRAESTEL 1 (FISIKA)

TABLE 1: PHYSICAL CONSTANTS/TABEL 1: FISIESTE KONSTANTES

| NAME/NAAM | SYMBOL/ SIMBOOL | VALUE/WAARDE |
|---|--------------------|---|
| Acceleration due to gravity / <i>Swaartekragversnelling</i> | g | 9,8 m•s ⁻² |
| Universal gravitational constant / <i>Universelegravitasiekonstant</i> | G | 6,67 × 10 ⁻¹¹ N•m ² •kg ⁻² |
| Speed of light in a vacuum / <i>Spoed van lig in 'n vakuüm</i> | c | 3,0 × 10 ⁸ m•s ⁻¹ |
| Planck's constant / <i>Planck se konstante</i> | h | 6,63 × 10 ⁻³⁴ J•s |
| Coulomb's constant / <i>Coulomb se konstante</i> | k | 9,0 × 10 ⁹ N•m ² •C ⁻² |
| Charge on electron / <i>Lading op elektron</i> | e | -1,6 × 10 ⁻¹⁹ C |
| Electron mass / <i>Elektronmassa</i> | m _e | 9,11 × 10 ⁻³¹ kg |
| Mass of earth / <i>Massa op aarde</i> | M | 5,98 × 10 ²⁴ kg |
| Radius of earth / <i>Radius van aarde</i> | R _E | 6,38 × 10 ³ km |

TABLE 2: FORMULAE/TABEL 2: FORMULES**MOTION/BEWEGING**

| | |
|---|---|
| $v_f = v_i + a \Delta t$ | $\Delta x = v_i \Delta t + \frac{1}{2} a \Delta t^2$ or/of $\Delta y = v_i \Delta t + \frac{1}{2} a \Delta t^2$ |
| $v_f^2 = v_i^2 + 2a\Delta x$ or/of $v_f^2 = v_i^2 + 2a\Delta y$ | $\Delta x = \left(\frac{v_i + v_f}{2} \right) \Delta t$ or/of $\Delta y = \left(\frac{v_i + v_f}{2} \right) \Delta t$ |

FORCE/KRAG

| | |
|---|-------------------------------|
| $F_{net} = ma$ | $w = mg$ |
| $\mu_k = \frac{f_k}{N}$ | $\mu_s = \frac{f_s^{max}}{N}$ |
| $F_{net} \Delta t = \Delta p$ $\Delta p = mv_f - mv_i$ | $p = mv$ |

| | |
|---|---|
| $F = \frac{Gm_1 m_2}{d^2}$ or/of $F = \frac{Gm_1 m_2}{r^2}$ | $g = \frac{GM}{d^2}$ or/of $g = \frac{GM}{r^2}$ |
|---|---|

WAVES, SOUND AND LIGHT/GOLWE, KLANK EN LIG

| | |
|---|---|
| $v = f \lambda$ | $T = \frac{1}{f}$ |
| $f_L = \frac{v \pm v_L}{v \pm v_s} f_s$ or/of $f_L = \frac{v \pm v_L}{v \pm v_b} f_b$ | $E = hf$ or/of $E = \frac{hc}{\lambda}$ |
| $E = W_0 + E_{k(\max)}$ or/of $E = W_0 + E_{k(\max)}$ | $W_0 = hf_0$ |
| $E_{k(\max)} = \frac{1}{2}mv_{\max}^2$ or/of $E_{k(\max)} = \frac{1}{2}mv_{\max}^2$ | |

ELECTROSTATICS/ELEKTROSTATIKA

| | |
|----------------------------|---|
| $F = \frac{kQ_1 Q_2}{r^2}$ | $E = \frac{F}{q}$ |
| $E = \frac{kQ}{r^2}$ | $n = \frac{Q}{q_e}$ or/of $n = \frac{Q}{e}$ |
| $V = \frac{W}{q}$ | |

ELECTROMAGNETISM/ ELEKTROMAGNETISME

| | |
|--|-------------------------|
| $\varepsilon = -N \frac{\Delta\Phi}{\Delta t}$ | $\Phi = BA \cos \theta$ |
|--|-------------------------|

ELECTRIC CIRCUITS/ELEKTRIESE STROOMBANE

| | |
|---|---------------------------|
| $I = \frac{q}{\Delta t}$ | $R = \frac{V}{I}$ |
| $\frac{1}{R_p} = \frac{1}{R_1} + \frac{1}{R_2} + \dots$ | $R_s = R_1 + R_2 + \dots$ |
| $W = Vq$ | $P = \frac{W}{\Delta t}$ |
| $W = VI\Delta t$ | $P = VI$ |
| $W = I^2 R \Delta t$ | $P = I^2 R$ |

| | |
|---|---------------------|
| $W = \frac{V^2 \Delta t}{R}$ | $P = \frac{V^2}{R}$ |
| emf (ε) = I(R + r) or/of emk (ε) = I(R + r) | |

WORK, ENERGY AND POWER/ARBEID, ENERGIE EN DRYWING

| | |
|---|---|
| $W = F \Delta x \cos \theta$ | $U = mgh$ or/of $E_p = mgh$ |
| $K = \frac{1}{2}mv^2$ or/of $E_k = \frac{1}{2}mv^2$ | $W_{\text{net}} = \Delta K$ or/of $W_{\text{net}} = \Delta E_k$ |
| $W_{\text{nc}} = \Delta K + \Delta U$ or/of $W_{\text{nc}} = \Delta E_k + \Delta E_p$ | $P = \frac{W}{\Delta t}$ |
| $P_{\text{ave}} = Fv_{\text{ave}}$ or/of $P_{\text{gem}} = Fv_{\text{gem}}$ | |

ALTERNATING CURRENT/WISSELSTROOM

| | |
|--|---|
| $I_{\text{rms}} = \frac{I_{\text{max}}}{\sqrt{2}}$ or/of $I_{\text{wgk}} = \frac{I_{\text{maks}}}{\sqrt{2}}$ | $P_{\text{ave}} = V_{\text{rms}} I_{\text{rms}}$ or/of $P_{\text{gem}} = V_{\text{wgk}} I_{\text{wgk}}$ |
| $V_{\text{rms}} = \frac{V_{\text{max}}}{\sqrt{2}}$ or/of $V_{\text{wgk}} = \frac{V_{\text{maks}}}{\sqrt{2}}$ | $P_{\text{ave}} = I_{\text{rms}}^2 R$ or/of $P_{\text{gem}} = I_{\text{wgk}}^2 R$ |
| | $P_{\text{ave}} = \frac{V_{\text{rms}}^2}{R}$ or/of $P_{\text{gem}} = \frac{V_{\text{gem}}^2}{R}$ |

GEGEWENS VIR FISIESE WETENSKAPPE GRAAD 12
VRAESTEL 2 (CHEMIE)
DATA FOR PHYSICAL SCIENCES GRADE 12
PAPER 2 (CHEMISTRY)

TABLE 1: PHYSICAL CONSTANTS/TABEL 1: FISIESE KONSTANTES

| NAME/NAAM | SYMBOL/SIMBOOL | VALUE/WAARDE |
|---|----------------|---|
| Avogadro's constant <i>Avogadro-konstante</i> | N_A | $6,02 \times 10^{23} \text{ mol}^{-1}$ |
| Charge on electron <i>Lading op elektron</i> | e | $-1,6 \times 10^{-19} \text{ C}$ |
| Electron mass <i>Elektronmassa</i> | m_e | $9,11 \times 10^{-31} \text{ kg}$ |
| Molar gas volume at STP <i>Molêre gasvolume by STD</i> | V_m | $22,4 \text{ dm}^3 \cdot \text{mol}^{-1}$ |
| Standard pressure <i>Standaarddruk</i> | p^\ominus | $1,013 \times 10^5 \text{ Pa}$ |
| Standard temperature <i>Standaardtemperatuur</i> | T^\ominus | 273 K |

TABLE 2: FORMULAE/TABEL 2: FORMULES

| | |
|---|---------------------|
| $n = \frac{m}{M}$ | $n = \frac{N}{N_A}$ |
| $c = \frac{n}{V}$ or/of $c = \frac{m}{MV}$ | $n = \frac{V}{V_m}$ |
| $K_w = [H_3O^+][OH^-] = 1 \times 10^{-14}$ at / by 298 K | |
| $E_{cell}^\ominus = E_{cathode}^\ominus - E_{anode}^\ominus / E_{sel}^\ominus = E_{katode}^\ominus - E_{anode}^\ominus$ | |
| or / of | |
| $E_{cell}^\ominus = E_{reduction}^\ominus - E_{oxidation}^\ominus / E_{sel}^\ominus = E_{reduksie}^\ominus - E_{oksidasie}^\ominus$ | |
| or / of | |
| $E_{cell}^\ominus = E_{oxidising\ agent}^\ominus - E_{redusing\ agent}^\ominus / E_{sel}^\ominus = E_{oksideermiddel}^\ominus - E_{reduseermiddel}^\ominus$ | |

THE PERIODIC TABLE OF ELEMENTS // DIE PERIODIEKE TABEL VAN ELEMENTE

| 1 (I) | 2 (II) | 3 | 4 | 5 | 6 | 7 | 8 | 9 | 10 | 11 | 12 | 13 (III) | 14 (IV) | 15 (V) | 16 (VI) | 17 (VII) | 18 (VIII) |
|------------------------|------------------------|-----------------------|------------------------|----------------------|-----------------------|-----------------------|------------------------|------------------------|------------------------|-------------------------|------------------------|------------------------|------------------------|------------------------|------------------------|-------------------------|-----------------|
| KEY / SLEUTEL | | | | | | | | | | | | | | | | | |
| 1 2,1 1 H | | | | | | | | | | | | | | | | | 2 He 4 |
| 3 1,0 7 Li | 4 1,5 9 Be | | | | | | | | | | | 5 2,0 11 B | 6 2,5 12 C | 7 3,0 14 N | 8 3,5 16 O | 9 4,0 19 F | 10 Ne 20 |
| 11 0,9 23 Na | 12 1,2 24 Mg | | | | | | | | | | | 13 1,5 27 Al | 14 1,8 28 Si | 15 2,1 31 P | 16 2,5 32 S | 17 3,0 35,5 Cl | 18 Ar 40 |
| 19 0,8 39 K | 20 1,0 40 Ca | 21 1,3 45 Sc | 22 1,5 48 Ti | 23 1,6 51 V | 24 1,6 52 Cr | 25 1,5 55 Mn | 26 1,8 56 Fe | 27 1,8 59 Co | 28 1,8 59 Ni | 29 1,9 63,5 Cu | 30 1,6 65 Zn | 31 1,6 70 Ga | 32 1,8 73 Ge | 33 2,0 75 As | 34 2,4 79 Se | 35 2,8 80 Br | 36 Kr 84 |
| 37 0,8 86 Rb | 38 1,0 88 Sr | 39 1,2 89 Y | 40 1,4 91 Zr | 41 Nb 92 | 42 1,8 96 Mo | 43 1,9 Tc | 44 2,2 101 Ru | 45 2,2 103 Rh | 46 2,2 106 Pd | 47 1,9 108 Ag | 48 1,7 112 Cd | 49 1,7 115 In | 50 1,8 119 Sn | 51 1,9 122 Sb | 52 2,1 128 Te | 53 2,5 127 I | 54 Xe 131 |
| 55 0,7 133 Cs | 56 0,9 137 Ba | 57 La 139 | 72 1,6 179 Hf | 73 Ta 181 | 74 W 184 | 75 Re 186 | 76 Os 190 | 77 Ir 192 | 78 Pt 195 | 79 Au 197 | 80 Hg 201 | 81 1,8 204 Tl | 82 1,8 207 Pb | 83 1,9 209 Bi | 84 2,0 Po | 85 2,5 At | 86 Rn |
| 87 0,7 Fr | 88 0,9 226 Ra | 89 Ac | | | | | | | | | | | | | | | |
| | | | 58 Ce 140 | 59 Pr 141 | 60 Nd 144 | 61 Pm | 62 Sm 150 | 63 Eu 152 | 64 Gd 157 | 65 Tb 159 | 66 Dy 163 | 67 Ho 165 | 68 Er 167 | 69 Tm 169 | 70 Yb 173 | 71 Lu 175 | |
| | | | 90 Th 232 | 91 Pa | 92 U 238 | 93 Np | 94 Pu | 95 Am | 96 Cm | 97 Bk | 98 Cf | 99 Es | 100 Fm | 101 Md | 102 No | 103 Lr | |

Atomic number

29

Elektronegatiwiteit

Electronegativity

1,9

Cu

Simbool

Symbol

Benaderde relatiewe atoommassa
Approximate relative atomic mass

63,5

**PHYSICAL SCIENCE
GRADE 12
CONTROLLED TEST
2026 TERM 1
MARKING GUIDELINES**

QUESTION 1**Reason**

1.1 D ✓✓ (2)

1.2 B ✓✓

$$v_f^2 = v_i^2 + 2gy$$

$$\text{At 3 m: } v_{1f}^2 = 0 + 2g(3) = 6g \dots\dots[1]$$

$$\text{At 9 m: } v_{2f}^2 = 0 + 2g(9) = 18g \dots \dots[2]$$

$$\text{From [1]: } v_{1f}^2 = 6g \Rightarrow g = \frac{v_{1f}^2}{6}$$

$$\text{Substitute [1] into [2]: } v_{2f}^2 = 18g \Rightarrow 18\left(\frac{v_{1f}^2}{6}\right) = 3v_{1f}^2$$

$$\text{Solve for } v_{2f}^2: v_{2f}^2 = 3v_{1f}^2 = \sqrt{3}v_{1f} \quad (2)$$

1.3 B ✓✓ (2)

1.4 D ✓✓ $F \propto \frac{mm}{r^2} \propto \frac{(1)(2)}{\left(\frac{1}{2}\right)^2} \propto \frac{2}{\frac{1}{4}} \propto 2 \div \frac{1}{4} \propto 2 \times \frac{4}{1} \propto 8$ (2)

1.5 C ✓✓ (2)

1.6 C ✓✓ (2)

1.7 A ✓✓ (2)

[14]

QUESTION 2

2.1 When a resultant/net force acts on an object, the object will accelerate in the direction of the force at an acceleration directly proportional to the force and inversely proportional to the mass of the object. ✓✓ (2)

2.2

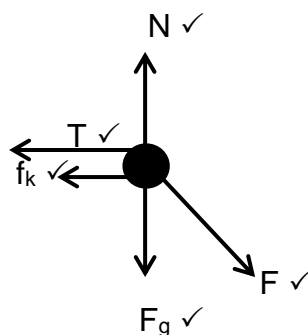

(5)

$$\begin{aligned}
 2.3.1 \quad & F_{net} = ma \\
 & F_{net} = 0 \\
 & F \cos \theta - T - f = 0 \\
 & F \cos \theta - T - \mu_k N = 0 \\
 & F \cos \theta - T - (\mu_k mg + 35 \sin 20^\circ) = 0 \\
 & 35 \cos 20^\circ - T - 0,2(6(9,8) + 35 \sin 20^\circ) \checkmark = 0 \checkmark \\
 & T = 18,74 \text{ N} \checkmark
 \end{aligned} \tag{4}$$

$$\begin{aligned}
 2.3.2 \quad & F_{net} = ma \\
 & F_{net} = 0 \\
 & T - (mg \sin \theta) - (\mu_k mg \cos \theta) = 0 \\
 & 18,74 - (m(9,8) \sin 30^\circ) - 0,15(m(9,8) \cos 30^\circ) \checkmark = 0 \checkmark \\
 & m = 3,04 \text{ kg} \checkmark
 \end{aligned} \tag{4}$$

[15]

QUESTION 3

3.1 Motion during which the only force acting on an object is the gravitational force. $\checkmark\checkmark$ (2)

3.2.1 80 m \checkmark (1)

3.2.2 9,8 m.s⁻² \checkmark ; downwards \checkmark (2)

3.3.1

| | |
|---|--|
| <p>OPTION 1 Upwards as positive</p> $v_f = v_i + at \checkmark$ $0 = v_i + (-9,8)(0,6) \checkmark$ $v_i = 5,88 \text{ m} \cdot \text{s}^{-1} \text{ upwards} \checkmark$ <p>OR</p> <p>Upwards as negative</p> $v_f = v_i + at \checkmark$ $0 = v_i + (9,8)(0,6) \checkmark$ $v_i = -5,88 \text{ m} \cdot \text{s}^{-1} \checkmark$ $\therefore 5,88 \text{ m} \cdot \text{s}^{-1} \text{ upwards} \checkmark$ | <p>OPTION 2 Upwards as positive</p> $\Delta y = v_i \Delta t + \frac{1}{2} a \Delta t^2 \checkmark$ $0 = v_i(1,2) + \frac{1}{2}(-9,8)(1,2)^2 \checkmark$ $v_i = 5,88 \text{ m} \cdot \text{s}^{-1} \text{ upwards} \checkmark$ <p>OR</p> <p>Upwards as negative</p> $\Delta y = v_i \Delta t + \frac{1}{2} a \Delta t^2 \checkmark$ $0 = v_i(1,2) + \frac{1}{2}(9,8)(1,2)^2 \checkmark$ $v_i = -5,88 \text{ m} \cdot \text{s}^{-1}$ $\therefore 5,88 \text{ m} \cdot \text{s}^{-1} \text{ upwards} \checkmark$ |
|---|--|

(3)

3.3.2

| | |
|--|---|
| <p>OPTION 1 $h = 80 - 55 \checkmark = 25 \text{ m} \checkmark$</p> | <p>OPTION 2 $h = -55 + 80 \checkmark = 25 \text{ m} \checkmark$</p> |
|--|---|

(2)

3.3.3

| Upwards as positive | Upwards as negative |
|--|--|
| $v_f^2 = v_i^2 + 2a\Delta y \checkmark$ | $v_f^2 = v_i^2 + 2a\Delta y \checkmark$ |
| $0^2 = v_i^2 + 2(-9,8)(60) \checkmark$ | $0^2 = v_i^2 + 2(9,8)(-60) \checkmark$ |
| $v_i = 34,293 \text{ m.s}^{-1} \text{ upwards} \checkmark$ | $v_i = 34,293 \text{ m.s}^{-1} \text{ upwards} \checkmark$ |

(3)

3.3.4

| Upwards as positive | Upwards as negative |
|---|---|
| $v_f^2 = v_i^2 + 2a\Delta y$ | $v_f^2 = v_i^2 + 2a\Delta y$ |
| $v_f^2 = (5,88)^2 + 2(-9,8)(-80) \checkmark$ | $v_f^2 = (-5,88)^2 + 2(9,8)(80) \checkmark$ |
| $v_f = 40,032 \text{ m.s}^{-1} \text{ downwards}$ | $v_f = 40,032 \text{ m.s}^{-1} \text{ downwards}$ |
| $v_f = v_i + at \checkmark$ | $v_f = v_i + at \checkmark$ |
| $-40,032 = 5,88 + (-9,8)\Delta t \checkmark$ | $40,032 = -5,88 + (9,8)\Delta t \checkmark$ |
| $\Delta t = 4,685 \text{ s}$ | $\Delta t = 4,685 \text{ s}$ |
| $v_f = v_i + at$ | $v_f = v_i + at$ |
| $0 = 34,293 + (-9,8)\Delta t \checkmark$ | $0 = -34,293 + (9,8)\Delta t \checkmark$ |
| $\Delta t = 3,499 \text{ s}$ | $\Delta t = 3,499 \text{ s}$ |
| $\Delta t = 4,685 + 3,499 = 8,184 \text{ s} \checkmark$ | $\Delta t = 4,685 + 3,499 = 8,184 \text{ s} \checkmark$ |

(5)

3.4 Marking Criteria

- Correct shape and ends at time, **t**. \checkmark
- Initial velocity. \checkmark
- Velocity at which it leaves the ground after the first bounce. \checkmark
- Time taken to reach maximum height for the first time. \checkmark

Upwards as positive

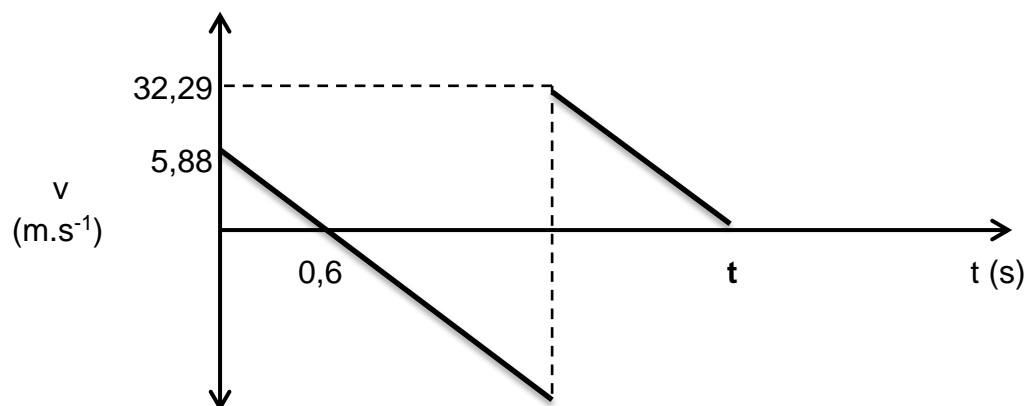

Upwards as negative

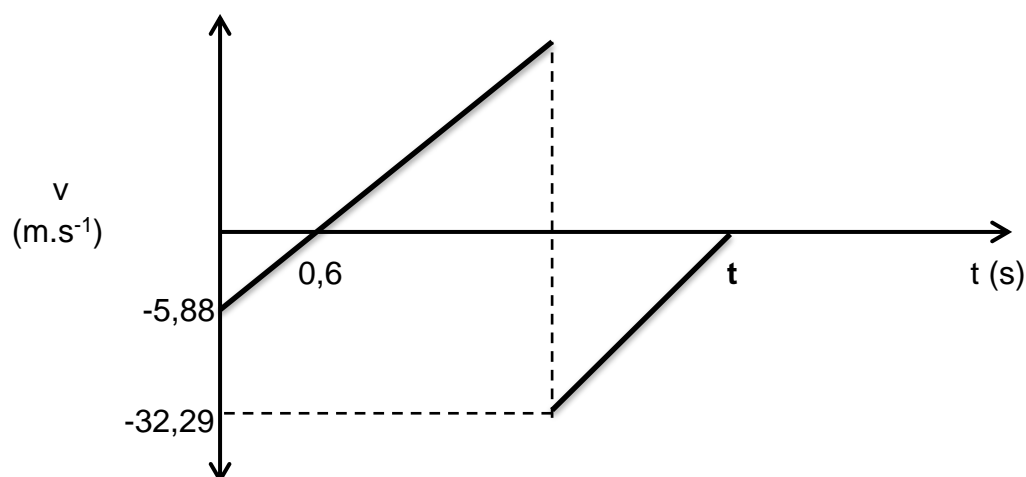

(4)

[22]

QUESTION 4

4.1 The TOTAL linear momentum of an isolated system remains constant (is conserved). ✓✓ (2)

4.2.1 $p = mv$ ✓
 $30\,000 = 2\,000 v$ ✓
 $v = 15\text{ m.s}^{-1}$ right ✓ (3)

4.2.2 $\Sigma p_i = \Sigma p_f$ ✓
 $2000(15) + m(0) = 2000(5) + m(20)$ ✓
 $m = 1\,000\text{ kg}$ ✓ (4)

4.3 $\Delta p = 20\,000\text{ kg.m.s}^{-1}$ ✓
 ← Arrow to the left ✓ (2)

4.4

| OPTION 1 | OPTION 2 |
|---------------------------------|---------------------------------|
| $F_{net}\Delta t = m\Delta v$ ✓ | $F_{net}\Delta t = m\Delta v$ ✓ |
| $F_{net}(0,5) = 2000(5 - 15)$ ✓ | $F_{net}(0,5) = 1000(20 - 0)$ ✓ |
| $F_{net} = -40\,000\text{ N}$ | $F_{net} = 40\,000\text{ N}$ ✓ |
| $F_{net} = 40\,000\text{ N}$ ✓ | |

(3)

4.5 For the same change in momentum. ✓
 During impact, the airbag increases the contact time. ✓
 The net force will decrease. ✓ (3)

[17]

QUESTION 5: ORGANIC CHEMISTRY

- 5.1 A bond or an atom or a group of atoms that determine(s) the physical and chemical properties of a group of organic compounds. ✓✓ (2)



- 5.3.1 F ✓ (1)

- 5.3.2 butanal ✓✓ (2)

- 5.3.3 2,3-dichloro✓-4,5-dimethyl✓heptane✓ (3)

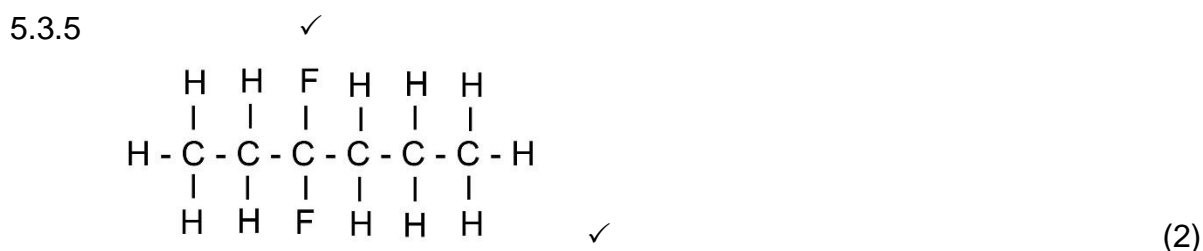

- 5.4.1 Organic molecules with the same molecular formula, but different structural formulae. ✓✓ (2)

- 5.4.2 Propan-1-ol ✓ and propan-2-ol ✓ (2)

- 5.5 Aldehydes ✓ and ketones ✓ **OR** carboxylic acids ✓ and esters ✓ (2)

[19]

QUESTION 6: ORGANIC CHEMISTRY

- 6.1 A series of organic compounds that can be described by the same general formula. ✓✓

OR

A series of organic compounds in which the members differ from the next

with a -CH_2 group. ✓✓ (2)

6.2 Alcohol ✓ (1)

6.3.1 Molecular mass ✓ (of different homologous series).
[Accept surface area/chain length/contact area] (1)

6.3.2 Vapour pressure ✓ (1)

6.3.3 The larger the molecular mass ✓, the lower the vapour pressure. ✓
OR
The smaller the molecular mass, the higher the vapour pressure.
[Accept surface area/chain length/contact area] (2)

6.4 Butane

- Weak London forces ✓ between its molecules.

OR

- London forces between its molecules.
- Less energy is needed for molecules to break out of liquid and form vapour.

OR ✓

Butan-1-ol

- Alcohol has stronger hydrogen bonds ✓ between its molecules.

OR

- Hydrogen bonds between its molecules.
- More energy is needed for molecules to break out of liquid and form vapour.

(3)

6.5 Compound **D** ✓ (butanol)

It has stronger hydrogen bonds ✓ between its molecules.

More energy is needed ✓ for molecules to break out of liquid and form vapour. [Accept it has lowest vapour pressure.] (3)

[13]

PAPER TOTAL: 100 MARKS

| TAXONOMY LEVELS | | | | | |
|--------------------------------|--------|---------------|-------------------------|-------------------------|-------|
| GRADE 12 | | | | | |
| PHYSICAL SCIENCES | | | | | |
| Control Test 1 - TERM 1 - 2026 | | | | | |
| MARKS: 100 | | | | | |
| QUESTION | RECALL | COMPREHENSION | ANALYSIS APPLICATION | EVALUATION SYNTHESIS | TOTAL |
| DESIRED % | 15% | 35% | 40% | 10% | 100% |
| 1.1 | 2 | | | | 2 |
| 1.2 | | | 2 | | 2 |
| 1.3 | | 2 | | | 2 |
| 1.4 | | | 2 | | 2 |
| 1.5 | | 2 | | | 2 |
| 1.6 | | 2 | | | 2 |
| 1.7 | | 2 | | | 2 |
| | | | | | |
| 2.1 | 2 | | | | 2 |
| 2.2 | | 5 | | | 5 |
| 2.3.1 | | | 4 | | 4 |
| 2.3.2 | | | 4 | | 4 |
| | | | | | |
| 3.1 | 2 | | | | 2 |
| 3.2.1 | | 1 | | | 1 |
| 3.2.2 | | 2 | | | 2 |
| 3.3.1 | | | 3 | | 3 |
| 3.3.2 | | | 2 | | 2 |
| 3.3.3 | | | 3 | | 3 |
| 3.3.4 | | | 5 | | 5 |
| 3.4 | | | | 4 | 4 |
| | | | | | |
| 4.1 | 2 | | | | 2 |
| 4.2.1 | | | 3 | | 3 |
| 4.2.2 | | | 4 | | 4 |
| 4.3 | | 2 | | | 2 |
| 4.4 | | | 3 | | 3 |
| 4.5 | | 3 | | | 3 |
| | | | | | |
| 5.1 | 2 | | | | 2 |
| 5.2 | | | | 1 | 1 |
| 5.3.1 | | 1 | | | 1 |
| 5.3.2 | | 2 | | | 2 |
| 5.3.3 | | 3 | | | 2 |
| 5.3.4 | | | | 2 | 2 |

| | | | | | |
|------------------|------------|------------|------------|------------|------------|
| 5.3.5 | | | | 2 | 2 |
| 5.4.1 | 2 | | | | 2 |
| 5.4.2 | | 2 | | | 2 |
| 5.5 | 2 | | | | 2 |
| | | | | | |
| 6.1 | 2 | | | | 2 |
| 6.2 | 1 | | | | 1 |
| 6.3.1 | | | 1 | | 1 |
| 6.3.2 | | | 1 | | 1 |
| 6.3.3 | | | 2 | | 2 |
| 6.4 | | 3 | | | 3 |
| 6.5 | | 3 | | | 3 |
| | | | | | |
| | | | | | |
| Total | 17 | 35 | 39 | 9 | 100 |
| Actual % | 17 | 35 | 39 | 9 | 100 |
| Desired % | 15% | 35% | 40% | 10% | 100 |